

Features

- ☆ Alle Vakuumsauger und Fittings sind schraubbar.
- ☆ Verschiedene Sicherungsmuttern enthalten, Außengewinde verfügen über Schlüsselansatzflächen.
- ☆ Für eine exakte Positionierung des Vakuumsaugers.
- ☆ Keine weiteren Montageelemente erforderlich, hohe Stabilität.



Abmessungen (mm)

Bestellcode Serie 18

10.018.1800

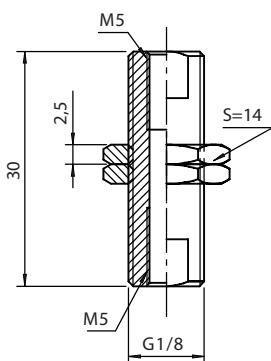

10.018.1812

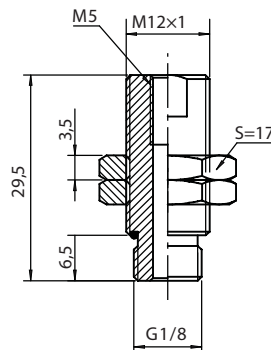

10.018.1205

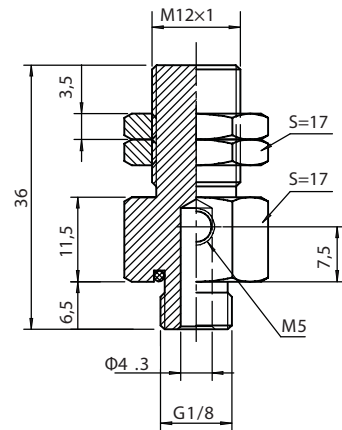

10.018.1814

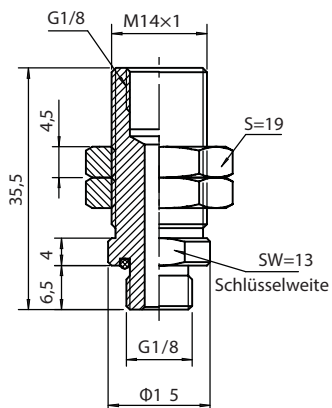

10.018.1405

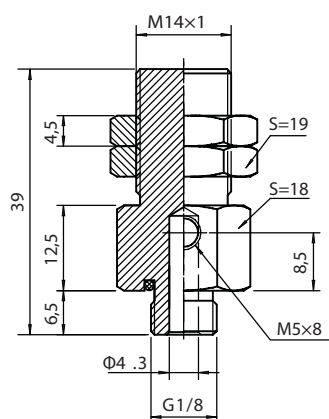

10.018.1816

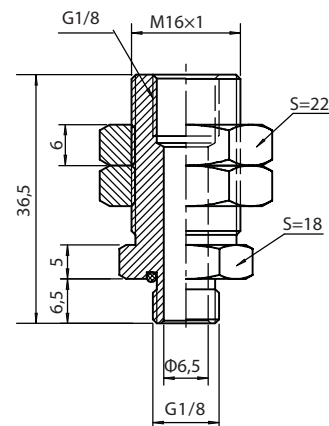

S: Schlüsselweite